



MicroPower Regulated Charge Pump

● Features

- Step-Up Voltage Converter
- Input Voltage Range: 2.7 to 5.0V
- MicroPower Consumption: 60µA
- Fixed 5V, 4.5V ± 4% Output
- Peak Current 250mA for 100ms
- High Frequency 750kHz Operation
- Logic-Controlled Shutdown
- Short-Circuit/Over-Temperature Protection
- Lead (Pb) Free SOT23-6 Package

● Applications

- Cellular Phones
- Digital Cameras
- Handheld Electronics
- LED/Display Backlight Driver
- LEDs for Camera Flash Portable
- Communication Devices
- MP3 Players
- GPS Receivers
- PDAs

● General Description

The FS1310 is a MicroPower switched capacitor voltage converter that delivers a regulated output. No external inductor is required for operation. The FS1310 can deliver up to 100mA to the voltage regulated output. It features very low quiescent current and high efficiency over a large portion of its load range, making this device ideal for battery-powered applications. Furthermore, the combination of few external components and small package size keeps the total converter board area to a minimum in space-restricted applications.

The FS1310 uses a pulse skipping technique to provide a regulated output from a varying input supply. The FS1310 contains a thermal management circuit to protect the device under continuous output short-circuit conditions. The FS1310 has lead (Pb) free SOT23-6 package and is rated over the -40° C to +85° C temperature range.

● Pin Configurations

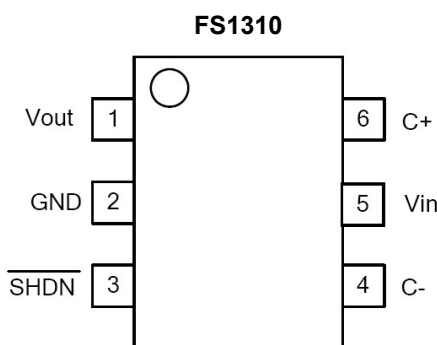

● Typical Application

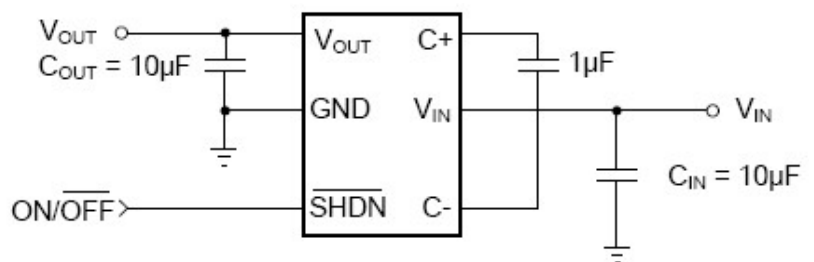

● Package/Ordering Information

| Order Number | Package Description | Package Option | Marking Information |
|--------------|---------------------|---------------------|---------------------|
| FS1310-5.0SL | SOT23-6 | Tape and Reel, 3000 | LAJ** |

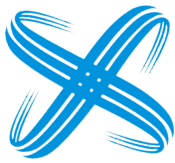

● Absolute Maximum Ratings

| | | | |
|-----------------------------------|-----------------|---|---------|
| VIN to GND | -0.3V to 6V | Package Thermal Resistance | |
| Vout to GND | -0.3V to 6V | SOT23-6, θ_{JA} | 250°C/W |
| SHDN to GND..... | -0.3V to 6V | Lead Temperature Range (Soldering 10 sec) | |
| Storage Temperature Range..... | -65°C to +150°C | | 260°C |
| Junction Temperature..... | 160°C | ESD Susceptibility | |
| Operating Temperature Range | -40°C to +85°C | HBM..... | 2000V |
| Power Dissipation, PD @ TA = 25°C | | MM..... | 400V |
| SOT23-6 | 0.34W | | |

NOTES:

Stresses above those listed under Absolute Maximum Ratings may cause permanent damage to the device. This is a stress Rating only; functional operation of the device at these or any other conditions above those indicated in the operational section of this specification is not implied. Exposure to absolute maximum rating conditions for extended periods may affect device reliability.

● Caution

This integrated circuit can be damaged by ESD if you don't pay attention to ESD protection. SGMICRO recommends that all integrated circuits be handled with appropriate precautions. Failure to observe proper handling and installation procedures can cause damage.

ESD damage can range from subtle performance degradation to complete device failure. Precision integrated circuits may be more susceptible to damage because very small parametric changes could cause the device not to meet its published specifications.

● Pin Description

| Name | Function |
|------|--|
| VOUT | Regulated output pin. |
| GND | Ground |
| SHDN | Shutdown input. Logic low signal disables the converter. |
| C- | Flying capacitor negative terminal. |
| VIN | Input supply pin. |
| C+ | Flying capacitor positive terminal. |



● Electrical Characteristics

(TA = -40°C to +85°C, unless otherwise noted. Typical values are at TA = 25°C, CFLY = 1μF, CIN = 10μF, COU = 10μF).

| Parameter | Symbol | Conditions | Min | Typ | Max | Units |
|--------------------------------|---------------------|--|------|-----|------------------|-------|
| FS1310-5.0 | | | | | | |
| Input Voltage Range | V _{IN} | V _{OUT} = 5.0V | 2.7 | | V _{OUT} | V |
| Output Voltage | V _{OUT} | 2.7V < V _{IN} < 5V, I _{OUT} ≤ 50mA | 4.8 | 5.0 | 5.2 | V |
| | | 3.0V < V _{IN} < 5V, I _{OUT} ≤ 100mA | 4.8 | 5.0 | 5.2 | |
| Quiescent Power Supply Current | I _Q | 2.7V < V _{IN} < 5V, I _{OUT} = 0mA, SHDN= V _{IN} | | 60 | 68 | μA |
| Shutdown Supply Current | I _{SHDN} | 2.7V < V _{IN} < 3.6V, I _{OUT} = 0mA, V _{SHDN} = 0 | | 0.2 | 1 | μA |
| | | 3.6V < V _{IN} < 5V, I _{OUT} = 0mA, V _{SHDN} = 0 | | | 1 | |
| Ripple Voltage | V _{RIPPLE} | V _{IN} = 2.7V, I _{OUT} = 50mA | | 15 | | mVP-P |
| | | V _{IN} = 3V, I _{OUT} = 100mA | | 88 | | |
| Efficiency | η | V _{IN} = 2.7V, I _{OUT} = 50mA | | 91 | | % |
| Frequency | f _{OSC} | Oscillator Free Running | | 750 | | kHz |
| SHDN Input Threshold High | V _{IH} | | 1.4 | | | V |
| SHDN Input Threshold Low | V _{IL} | | | | 0.4 | |
| SHDN Input High Current | I _{IH} | SHDN= V _{IN} | -1 | | +1 | μA |
| SHDN Input Low Current | I _{IL} | SHDN = GND | -1 | | +1 | μA |
| Turn-On Time | T _{ON} | V _{IN} = 3V, I _{OUT} = 0mA | | 0.3 | | ms |
| FS1310-4.5 | | | | | | |
| Input Voltage Range | V _{IN} | V _{OUT} = 4.5V | 2.7 | | V _{OUT} | V |
| Output Voltage | V _{OUT} | 2.7V < V _{IN} < 4.5V, I _{OUT} ≤ 50mA | 4.32 | 4.5 | 4.68 | V |
| | | 3.0V < V _{IN} < 4.5V, I _{OUT} ≤ 100mA | 4.32 | 4.5 | 4.68 | |
| Quiescent Power Supply Current | I _Q | 2.7V < V _{IN} < 4.5V, I _{OUT} 0mA, SHDN= V _{IN} | | 60 | 68 | μA |
| Shutdown Supply Current | I _{SHDN} | 2.7V < V _{IN} < 3.6V, I _{OUT} = 0mA, V _{SHDN} = 0 | | 0.2 | 1 | μA |
| | | 3.6V < V _{IN} < 4.5V, I _{OUT} = 0mA, V _{SHDN} = 0 | | | 1 | |
| Ripple Voltage | V _{RIPPLE} | V _{IN} = 2.7V, I _{OUT} = 50mA | | 15 | | mVP-P |
| | | V _{IN} = 3V, I _{OUT} = 100mA | | 88 | | |
| Efficiency | η | V _{IN} = 2.7V, I _{OUT} = 50mA | | 83 | | % |
| Frequency | f _{OSC} | Oscillator Free Running | | 750 | | kHz |
| SHDN Input Threshold High | V _{IH} | | 1.4 | | | V |
| SHDN Input Threshold Low | V _{IL} | | | | 0.4 | |
| SHDN Input High Current | I _{IH} | SHDN= V _{IN} | -1 | | +1 | μA |
| SHDN Input Low Current | I _{IL} | SHDN = GND | -1 | | +1 | μA |
| Turn-On Time | T _{ON} | V _{IN} = 3V, I _{OUT} = 0mA | | 0.3 | | ms |

Specifications subject to changes without notice.



● Typical Performance Characteristics

At $V_S = +5.0V$, $T_A = +25^\circ C$, $V_{IN} = 3V$, $C_{IN} = C_{OUT} = 10\mu F$, $C_{FLY} = 1\mu F$, unless otherwise noted.

Startup Time with 50mA Load

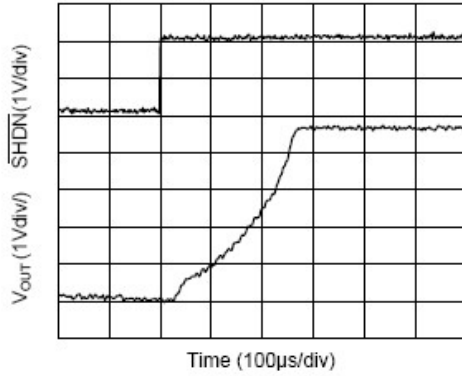

Startup Time with 100mA Load

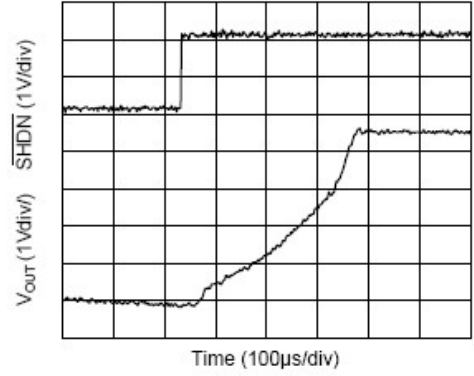

Output Ripple with $I_{OUT} = 50mA$

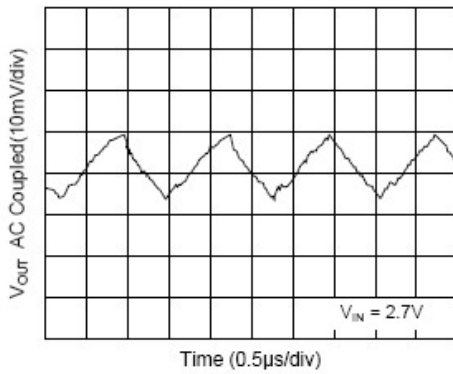

Output Ripple with $I_{OUT} = 100mA$

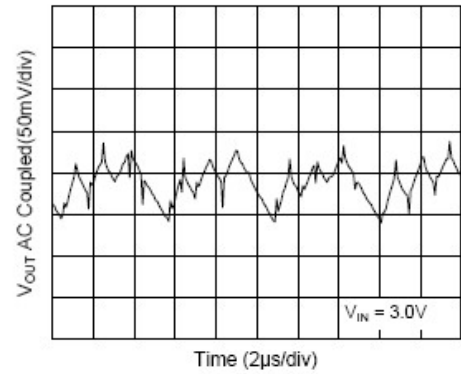

Load Transient Response for 50mA

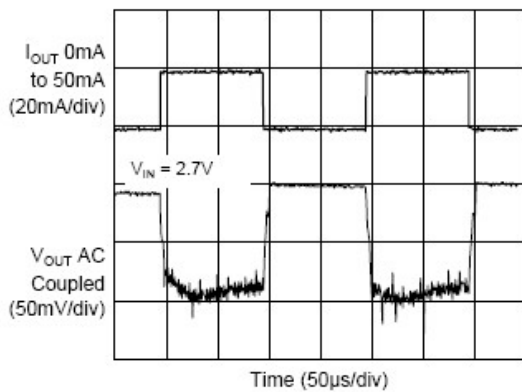

Load Transient Response for 100mA

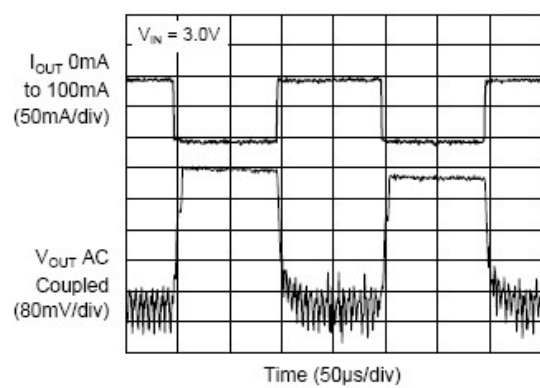

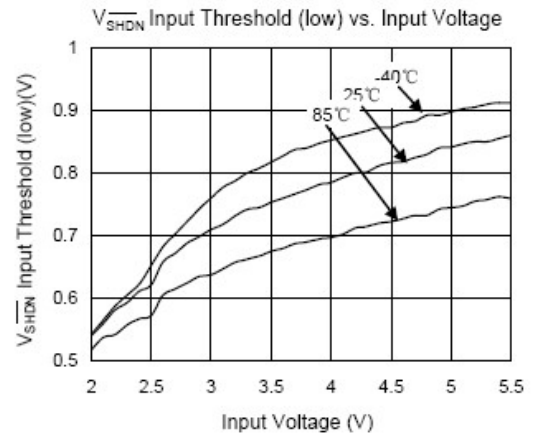
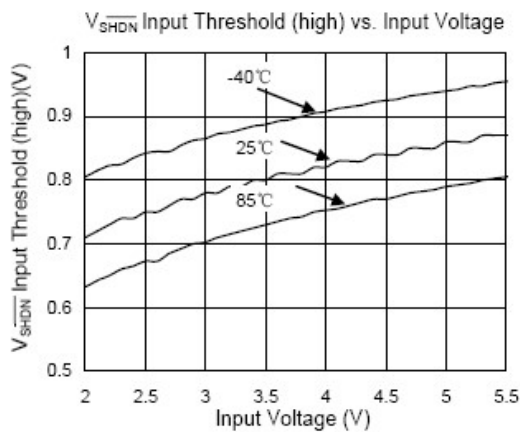
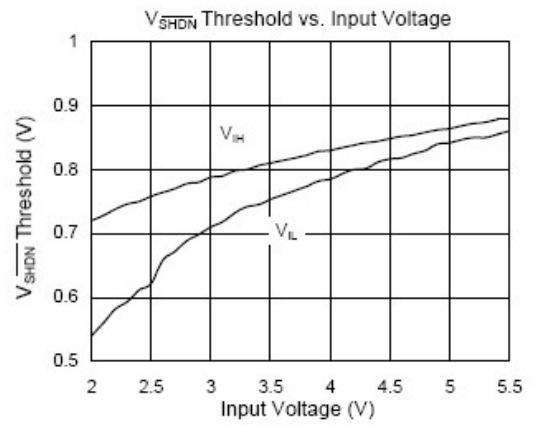
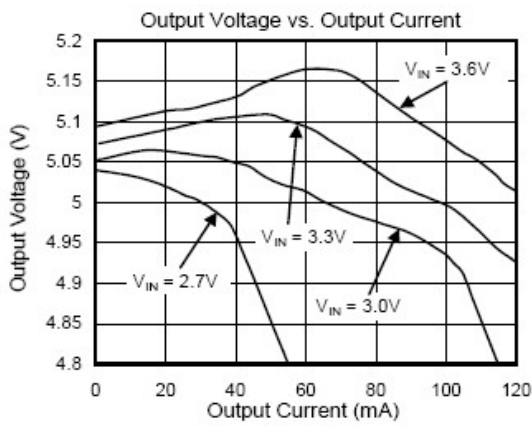
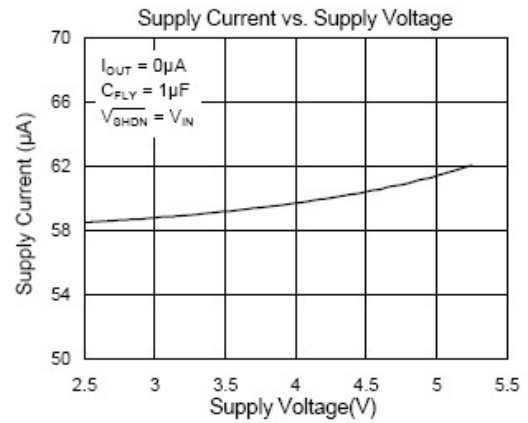
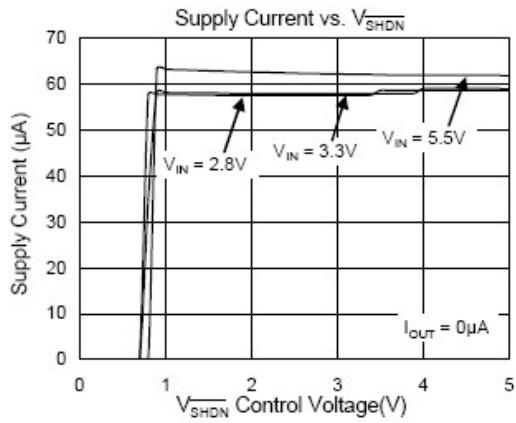

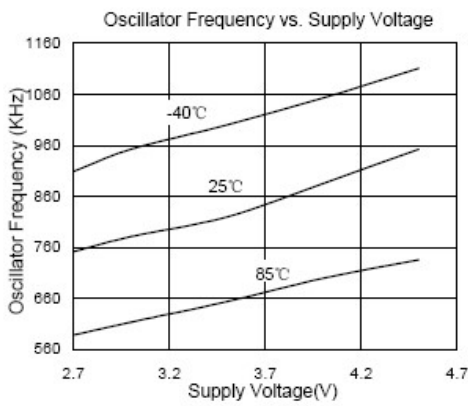
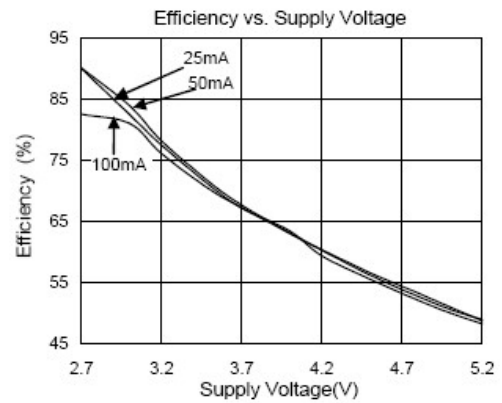
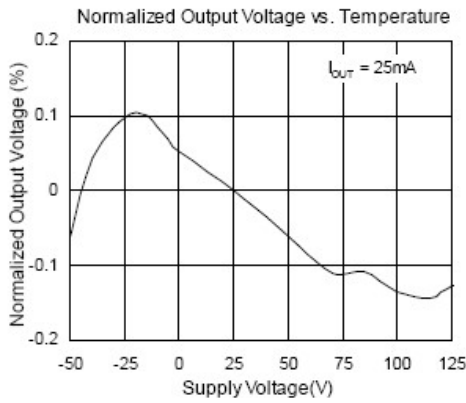

● Package Information

SOT23-6

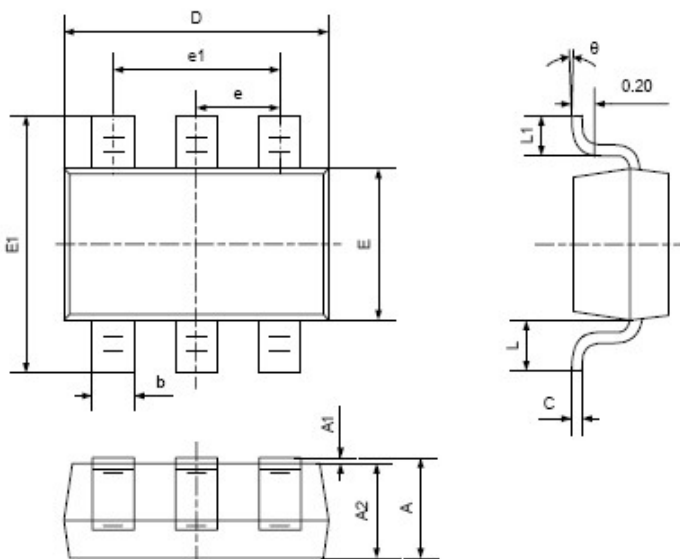

| Symbol | Dimensions In Millimeters | | Dimensions In Inches | |
|--------|---------------------------|-------|----------------------|-------|
| | Min | Max | Min | Max |
| A | 1.050 | 1.250 | 0.041 | 0.049 |
| A1 | 0.000 | 0.100 | 0.000 | 0.004 |
| A2 | 1.050 | 1.150 | 0.041 | 0.045 |
| b | 0.300 | 0.400 | 0.012 | 0.016 |
| C | 0.100 | 0.200 | 0.004 | 0.008 |
| D | 2.820 | 3.020 | 0.111 | 0.119 |
| E | 1.500 | 1.700 | 0.059 | 0.067 |
| E1 | 2.650 | 2.950 | 0.104 | 0.116 |
| e | 0.950TYP | | 0.037TYP | |
| e1 | 1.800 | 2.000 | 0.071 | 0.079 |
| L | 0.700REF | | 0.028REF | |
| L1 | 0.300 | 0.600 | 0.012 | 0.024 |
| θ | 0° | 8° | 0° | 8° |